

**MELISSA AIR 7XUP! S1**

Gruppo estetico / Aesthetic group / Ästhetische Gruppe / Groupe esthétique / Grupo estético

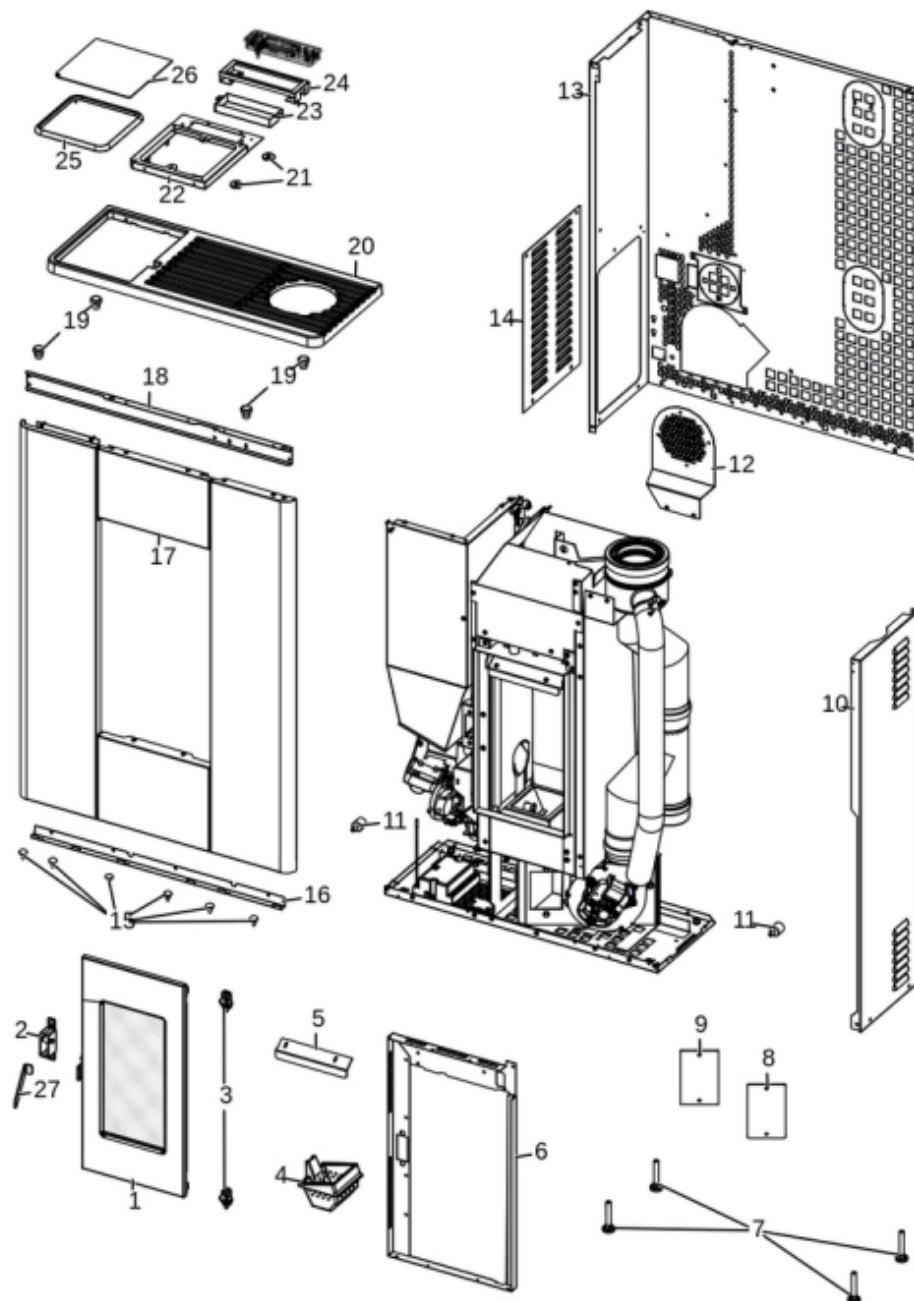

N°	Codice/Code	Descrizioni / Description / Beschreibung / Description / Descripción
1	41402077050	Porta ghisa completa / Complete cast iron door / Komplette Tür aus Güsseisen / Porte en fonte complète / Puerta completa de arrabio
2	41411653960	Supporto chiusura porta / Door closing support / Türschließ Halterung / Support de fermeture de porte / Soporte de cierre de puerta
3	41202007420	Kit 2 cerniere porta asolate / Kit of 2 slotted door hinges / Kit mit 2 geschlitzten Türscharnieren / Kit de 2 charnières de porte à fente / Kit de 2 bisagras ranuradas
4	4130200320000	Crogiolo in ghisa / Cast iron crucible / Brenntopf aus Gusseisen / Creuset en fonte / Brasero de arrabio
5	4140207803000	Deflettore pulizia vetro / Glass cleaning deflector / Leitblech für Glassreinigung / Deflecteur pour nettoyage du verre / Deflector por limpieza vidrio
6	4140207863100	Cornice frontale / Front frame / Vorderer Rahmen / Cadre avant / Marco frontal
7	41200906660	Piedini di appoggio (4 pz.) / Support feet (4 pcs.) / Einstellfüße (4 Stck.) / Vérins d'appui (4 p.es) / Pies de apoyo (4 piezas)
8	41402077910	Tappo / Plug / Verchluss / Clapet / Tapón

9	41802002400	Guarnizione tappo struttura / Structure plug gasket / Dichtung der Strukturklappe / Joint clapet structure / Junta tapón estructura
10	4140219263000	* / * / * / * / *
11	41201105600	Antivibranti (10 pz) / anti-vibration mountings (10 pcs) / Schwingungsdämpfer (10 Stck) / Éléments antivibratoires (10 pcs) / Anti-vibraciones (10 pz)
12	41402246550	* / * / * / * / *
13	4140222623000	* / * / * / * / *
14	4140222613100	* / * / * / * / *
15	41801002300	Paracolpi in silicone Ø 8/5 (2pz) / Silicone bumpers Ø 8/5 (2pcs) / Schlagschutzgummi Ø 8/5 (2 Stck) / Pièces silicone antichoc Ø 8/5 (2pcs) / Anti-golpes en silicona Ø 8/5 (2pzs)
16	41402182330	* / * / * / * / *
17	6921036	* / * / * / * / *
17	6921037	* / * / * / * / *
17	6921038	* / * / * / * / *
17	6921039	* / * / * / * / *
18	41402188830	* / * / * / * / *
19	4120180	Gommini paracolpi (4 pz) / Rubber bumpers (4 pcs.) / Schlagschutzgummi (4 Stck) / Pièces caoutchouc antichoc (4 pcs) / Cauchitos anti-golpes (4 pz)
20	4130201080000	* / * / * / * / *
21	41801657900	Magneti (pz.2) / Magnet (pcs.2) / Magnet (stk. 2) / Aimant (pcs.2) / Imán (pz.2)
22	4140207813000	Tamponazione serbatoio / Filling Rear / Tank Stopfung / Tampon réservoir / Taponado depósito
23	41402078230	Scatola pannello comandi / Control panel box / Schachtel Bedienblende / Boîte tableau de commandes / Caja panel de mandos
24	4140208573000	Supporto pannello comandi / Control panel support bracket / Bedienblende Halterung / Support panneau des commandes / Soporte panel de mandos
25	41801604700	Guarnizione tenuta serbatoio / Pellet hopper gasket / Pelletbehälter Dichtung / Joint réservoir pellet / Junta depósito pellet
26	4140210701000	Coperchio / Cover / Deckel / Couvercle / Tapa
27	41331700560	* / * / * / * / *

## MELISSA AIR 7XUPI S1

Gruppo camera di combustione / Combustion chamber group / Verbrennungskammer Gruppe / Group de chambre de combustion / Grupo cámara de combustión

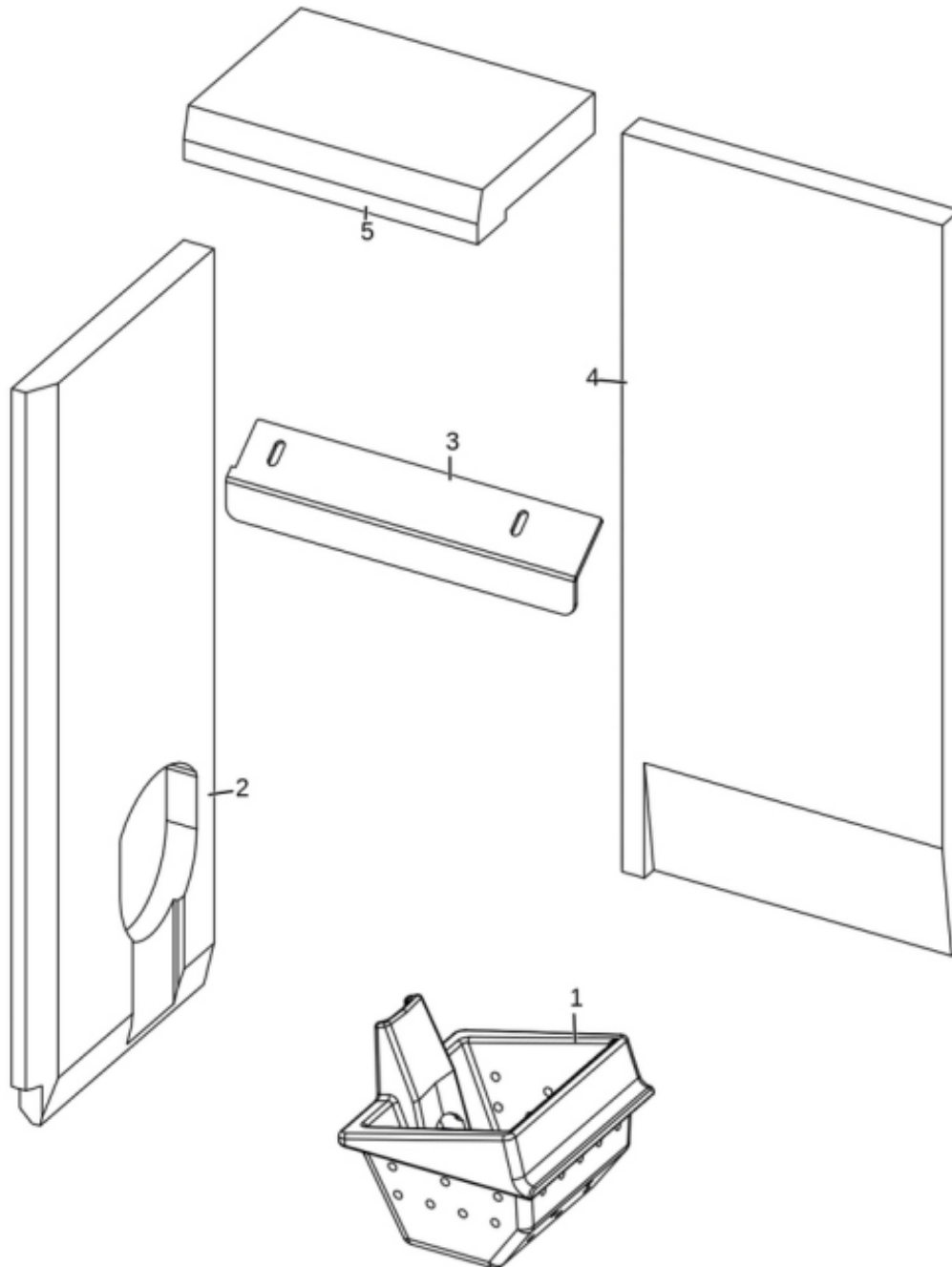

N°	Codice/Code	Descrizioni / Description / Beschreibung / Description / Descripción
1	4130200320000	Crogiolo in ghisa / Cast iron crucible / Brennertopf aus Gusseisen / Creuset en fonte / Brasero de arrabio
2	41152006900	* / * / * / * / *
3	4140207803000	Deflettore pulizia vetro / Glass cleaning deflector / Leitblech für Glassreinigung / Deflecteur pour nettoyage du verre / Deflector por limpieza vidrio
4	41152007000	* / * / * / * / *
5	41152001600	Deflettore vermiculite / Vermiculite deflector / Leitblech aus Vermiculite / Déflecteur en vermiculite / Deflector en vermiculite

## MELISSA AIR 7XUP! S1

Porta fuoco / Fire door / Feuertür / Porte foyer / Puerta hogar

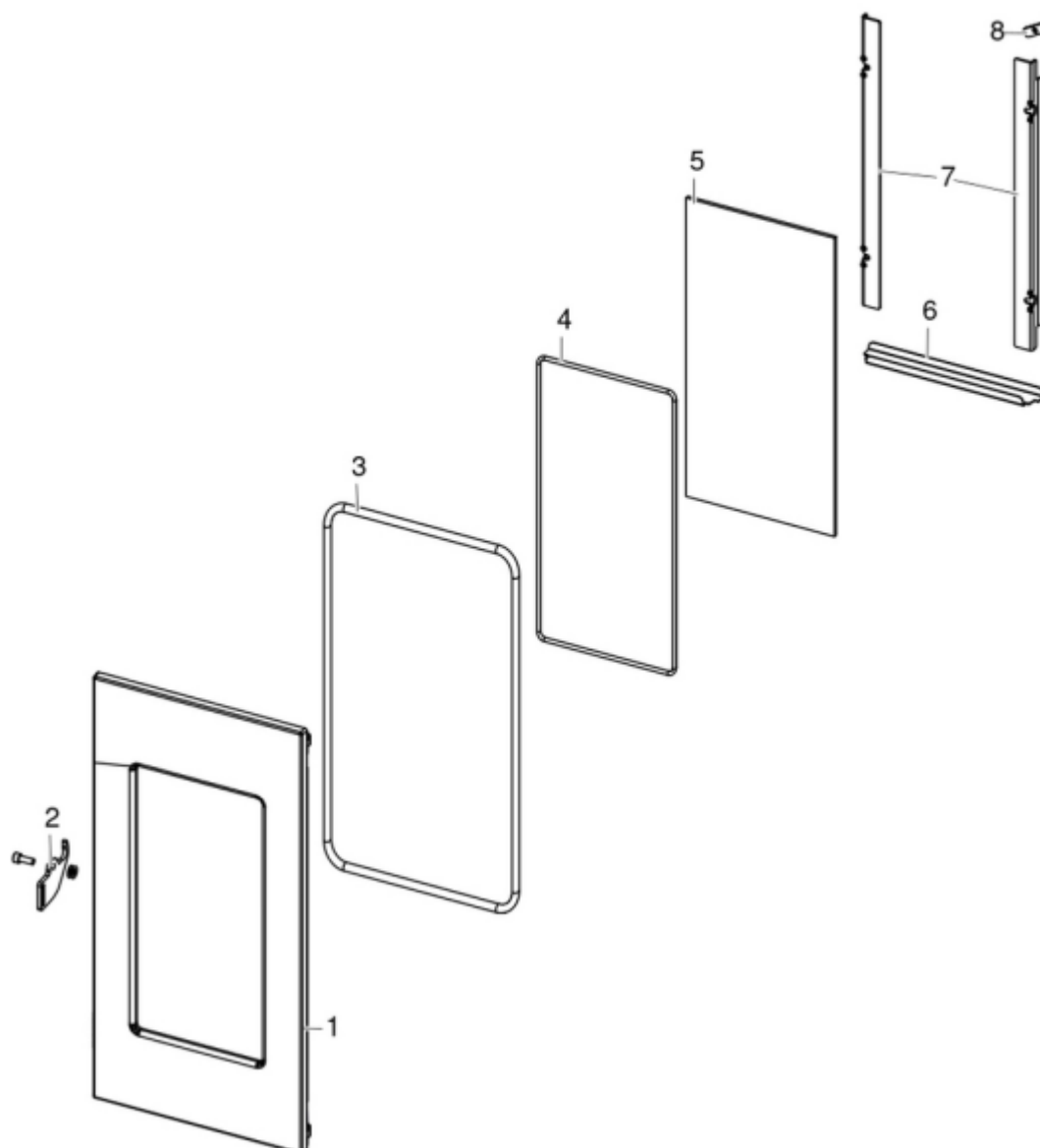

N°	Codice/Code	Descrizioni / Description / Beschreibung / Description / Descripción
1	4130200542000	Porta in ghisa / Cast iron door / Gusseisentür / Porte en fonte / Puerta de arrabio
2	41402055990	Maniglia porta / Door Handle / Türgriff / Poignée porte / Tirador de la puerta
3	4120103A	Cordino fibroceramico Ø 10 mm (5 mt.) / Ceramic fibre cord Ø 10 mm (5 m) / Keramikfaserschnur Ø 10 mm (5 m) / Cordon en fibre céramique Ø 10 mm (5 m) / Junta a cuerda de fibra cerámica Ø 10 mm (5 m)
3	4120103B	Cordino fibroceramico Ø 10 mm (50 mt.) / Ceramic fibre cord Ø 10 mm (50 m) / Keramikfaserschnur Ø 10 mm (50 m) / Cordon en fibre céramique Ø 10 mm (50 m) / Junta a cuerda de fibra cerámica Ø 10 mm (50 m)
4	41801603300A	Guarnizione Ø5 5mt / Gasket Ø5 5mt / Dichtung Ø5 5mt / Joint Ø5 5mt / Junta Ø5 5mt
4	41801603300B	Guarnizione Ø5 50mt / Gasket Ø5 50mt / Dichtung Ø5 50mt / Joint Ø5 50mt / Junta Ø5 50mt
4	41801603300C	Guarnizione Ø5 5mt + silicone / Gasket Ø5 5mt + silic / Dichtung Ø5 5mt + Silikon / Joint Ø5 5mt + silic / Junta Ø5 5mt
5	41702002200	Vetro ceramico / Ceramic glass / Glaskeramikscheibe / Vitrocéramique / Cristal cerámico
6	41402076030	Raccogli cenere porta / Door ash-collection compartment / Türasche Sammelfach / Compartiment de collecte des cendres de porte / Compartimento de recogida de cenizas en la puerta
7	4140208133000	Fermavetro laterale porta / Lateral glass fastening bracket / Seitenhaltebügel für Scheibebefestigung / Etrier laterale de fixation vitrocéramique / Retendor lateral del cristal
8	41402076510	Blocco porta / Door stop / Türstopper / Stop pour porte / Tope por puerta

## MELISSA AIR 7XUP! S1

Gruppo caricamento pellet / Pellet feed group / Pellet Fördergruppe / Groupe chargement du pellet / Grupo de carga pellet

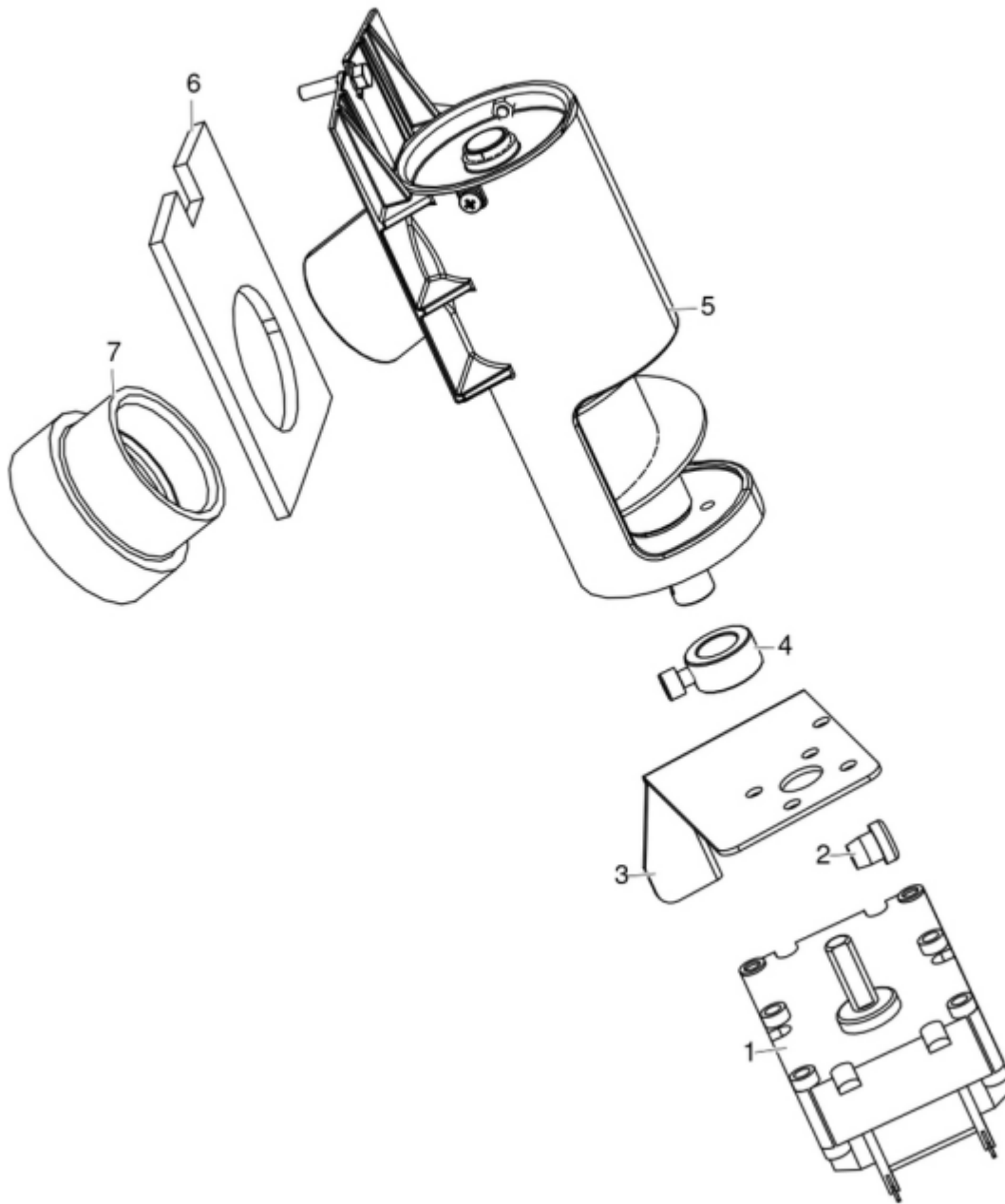

N°	Codice/Code	Descrizioni / Description / Beschreibung / Description / Descripcion
1	41451602400	Motoriduttore 2rpm Merkle Korff senza encoder / Reduction motor 2 rpm Merkle Korff without encoder / Getriebemotor 2 rpm Merkle Korff ohne Encoder / Motorréducteur 2 rpm Merkle Korff sans codeur / Motorreductor 2 rpm Merkle Korff sin encoder
2	4120180	Gommini paracolpi (4 pz) / Rubber bumpers (4 pcs.) / Schlagschutzgummi (4 Stck) / Pièces caoutchouc antichoc (4 pcs) / Cauchitos anti-golpes (4 pz)
3	41402075830	Supporto motoriduttore / Gearmotor support / Schneckenmotor Gestell / Support motorréducteur / Soporte motorreductor
4	4120398	Connettore motoriduttore-coclea / Reduction motor-feed screw connector / Verbindung Getriebemotor-Schnecke / Connecteur motorréducteur-vis sans fin / Conector motorreductor-cóclea
5	41402015750	Gruppo alimentazione / Complete feed screw / Komplette Förderschnecke / Vis sans fin complète / Cóclea de carga completa
6	41802000300	Guarnizione / Gasket / Dichtung / Joint / Junta
7	41801702600	Guarnizione / Gasket / Dichtung / Joint / Junta



## MELISSA AIR 7XUP! S1

Gruppo elettrico ed elettronico / Electrical and electronic group / Elektrische und elektronische Gruppe / Groupe électrique et électronique / Grupo eléctrico y electrónico

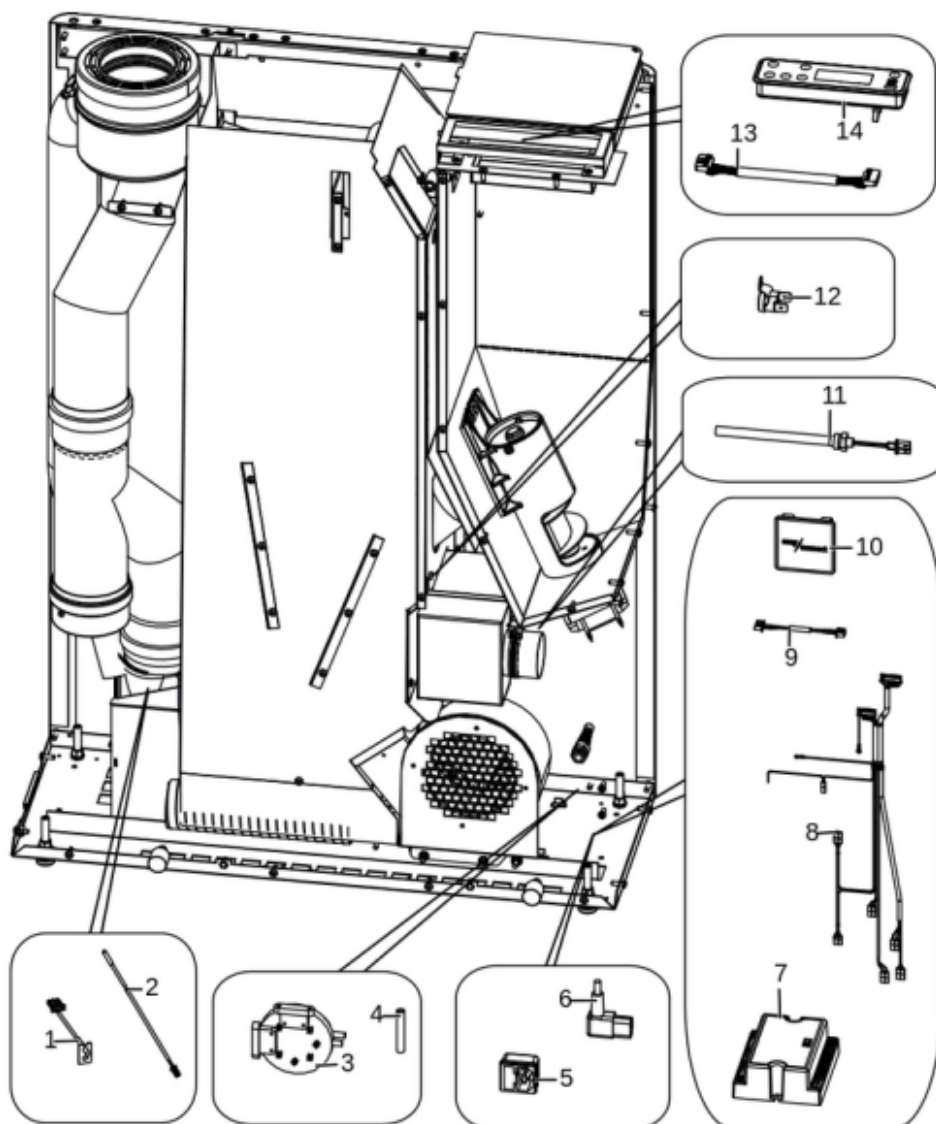

N°	Codice/Code	Descrizioni / Description / Beschreibung / Description / Descripción
1	41451401300	Sonda fumi con flangia / Smoke sensor with flange / Rauchsonde mit Flansche / Sonde fumées avec bride / Sonda humos con brida
2	41452001500	Sonda ambiente / Room temperature sensor / Raumtemperaturfühler / Sonde température ambiance / Sonda temperatura ambiente
3	41451003700	Pressostato / Pressure switch / Druckschalter / Pressostat / Presostato
4	4120631A	Tubicino siliconico - 5m / Silicon tube - 5m / Silikonrohr - 5m / Petit tuyau en silicone - 5m / Tubo silicónico - 5m
5	41451104100	Presa con fusibile / Socket with fuse / Steckdose mit Sicherung / Prise avec fusible / Toma con fisible
6	41451603300	Cavo alimentazione / Power cable / Stromkabel / Câble d'alimentation / Cable alimentación
7	41452002300	Scheda madre neutra MICRONOVA / Unprogrammed motherboard MICRONOVA / Unprogrammierte Hauptplatine MICRONOVA / Carte mère non programmée MICRONOVA / Tarjeta madre sin programa MICRONOVA
7	41452002300B	Scheda madre / Motherboard / Hauptplatine / Carte mère / Tarjeta madre
8	41452004101	Cablaggio completo / Complete wiring / Komplette Verkabelung / Câblage complet / Cableado completo
9	41452002500	Cavo flat / Flat cable / Flat-Kabel / Cable flat / Flat cable
10	4020003	Wi-Fi Easy Connect / Wi-Fi Easy Connect / Wi-Fi Easy Connect / Wi-Fi Easy Connect / Wi-Fi Easy Connect
11	41452002000	Candeletta / Sparkplug / Zündkerze / Bougie / Bujía
12	412007004	Clickson 110°C / Clickson 110°C / Clickson 110°C / Clickson 110°C / Clickson 110°C
13	41451201900	Cavo Flat L 1,4 M / Flat cable L 1,4 M / Flat Kable L 1,4 M / Câble Flat L 1,4 M / Cable Flat L 1,4 M
14	41451200600	Pannello comandi / Control panel / Bedienblende / Panneau de commande / Panel de mandos

**MELISSA AIR 7XUP! S1**

Gruppo fumi / Smoke group / Rauchgruppe / Groupe fumées / Grupo de humos

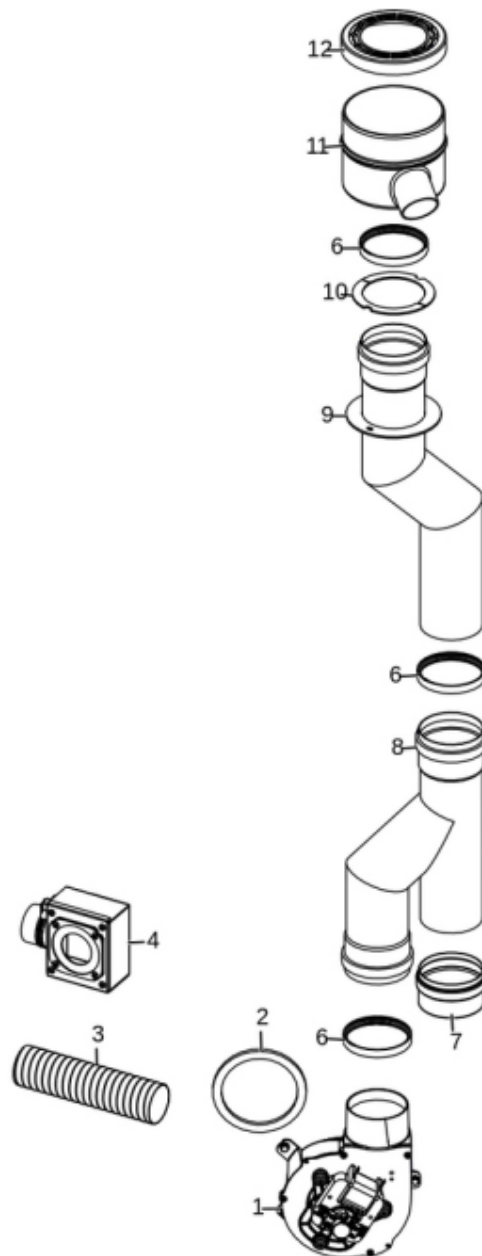

N°	Codice/Code	Descrizioni / Description / Beschreibung / Description / Descripción
1	41452005301	Ventilatore Fumi / Smoke exhaust fan / Rauchabsauggebläse / Ventilateur aspiration fumées / Ventilador aspiración de humos
1	41452009200	Encoder per ventilatore fumi marchio EMC / Encoder for EMC smoke fan / Encoder für EMC Rauchgasgebläse / Encoder pour ventilateur des fumées marque EMC / Encoder para ventilador humos marca EMC
2	41802004900	Guarnizione estrattore fumi Ø120 / Smoke extractor gasket Ø120 / Rauchabzugsdichtung Ø120 / Joint d'extraction de fumée Ø120 / Junta extractor de humos Ø120
3	41802012100	* / * / * / * / *
4	4140215304000	Scatola ingresso aria / Air inlet box / Lufteinlass Kasten / Boîtier d'entrée d'air / Caja de entrada de aire
6	40120969	Guarnizione silicone (5pz) / Silicone Gasket (5pc.) / Silikondichtung (5 St.) / Joint en silicone / Junta en silicona
7	41601900900	Tappo raccordo T Ø 80 / Plug T connection Ø 80 / Verchluss T Verbindung Ø 80 / Clapé raccord en T Ø 80 / Tapón raccord T Ø 80
8	4160200980000	* / * / * / * / *
9	4160200990000	* / * / * / * / *
10	4140215321000	Disco centraggio / Centering disc / Zentrierscheibe / Disque de centrage / Disco de centrado
11	4131200170000	Raccordo scarico superiore / Upper smoke outlet connection / Oberer Rauchabzugsanschluss / Connexion de sortie de fumée supérieure / Conexión de salida de humos superior
12	4140215513000	Tappo raccordo scarico superiore / Upper drain connection cap / Obere Ablaufanschluss Kappe / Bouchon supérieur de raccordement de vidange / Tapa de conexión de drenaje superior

## MELISSA AIR 7XUP! S1

Gruppo ventilazione / Ventilation group / Lüftungsgruppe / Groupe de ventilation / Grupo de ventilación

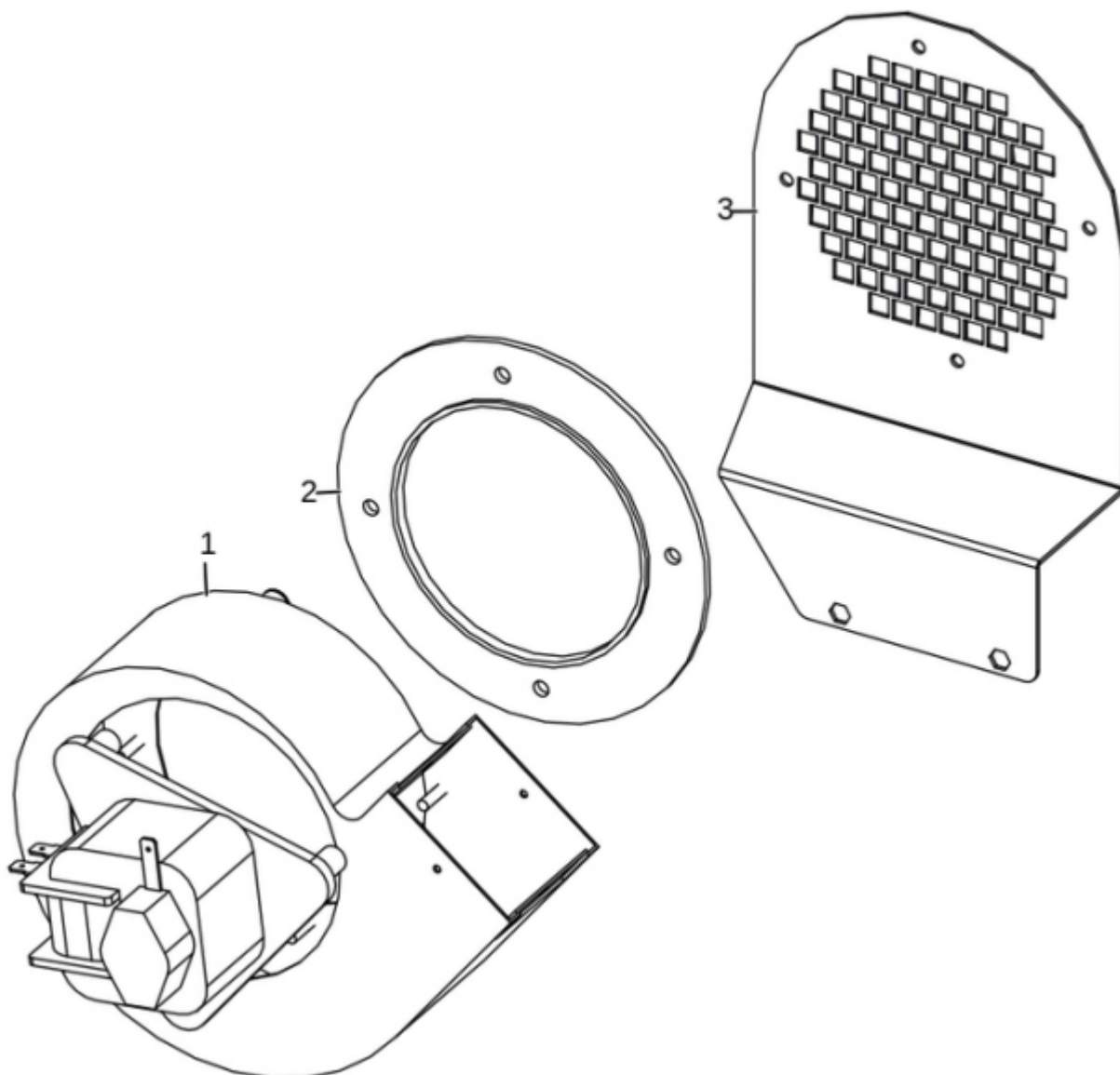

N°	Codice/Code	Descrizioni / Description / Beschreibung / Description / Descripción
1	41451203800	Ventilatore centrifugo SX / L.Air fun / L.Luftgebläse / Ventilateur air G. / Ventilador aire IZDO
2	418008018	Guarnizione ventilatore / Fan gasket / Dichtung des Gebläses / Joint du ventilateur / Junta ventilador
3	41402246550	* / * / * / * / *